



OUR MARKET IS THE WORLD

Buckau-Wolf GmbH is a globally active, owner-managed company with a long tradition specializing in special machinery.

We are experts in industrial mixing and separation processes for a variety of applications. We offer our customers the reliability of a supplier that has been established for decades, modern control technology, competent staff and flexible service.

Whether with spare parts, maintenance, inspection, security conversions or rental machines – **qualified, reliable and flexible**

WORLDWIDE SERVICES

Technical expertise

- Spare parts for all Buckau-Wolf machines
- Recurring tests according to DGUV and on site balancing
- Machine analysis, modernization of existing centrifugals and process optimization
- Innovative concepts for operating centrifugals and process monitoring
- Maintenance and repair at our workshop or on site

Buckau-Wolf GMBH

Nordstraße 41
41515 Grevenbroich
Germany

Phone: +49 2181 602-400
Fax: +49 2181 602-342

www.buckau-wolf.com
supraton@buckau-wolf.com



Buckau-Wolf



BUCKAU-WOLF
SUGAR
TECHNOLOGY

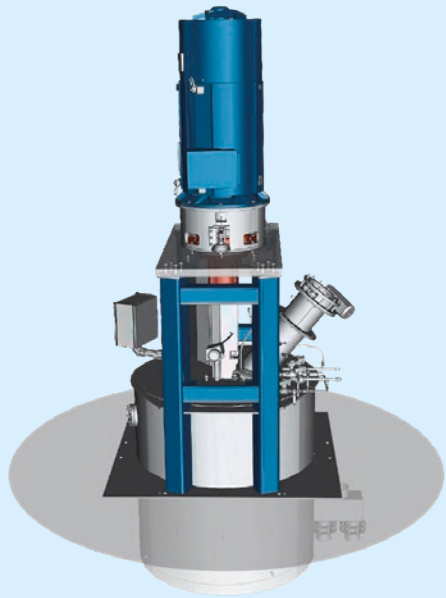

BATCH CENTRIFUGALS

Highest production output

- Slim basket design
- Separation factor up to 1,500 (dextrose) and 1,250 (sugar)
- Discoloration of 98 %
- Residual moisture for white sugar massecuites is 0.5 %
- Modern diagnostic system, user-friendly panel surface and high degree of automation

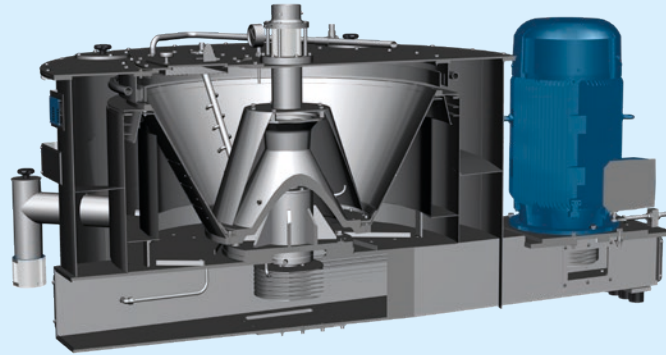

CONTINUOUS CENTRIFUGALS

Robust and ergonomic design

- Simple sampling on the operator level
- Available as dry - or liquid discharge version
- Integral steam feeding for reduction of massecuite viscosity and increased separation efficiency
- Optimum control of massecuite feeding via PLC
- User-friendly panel



VACUUM PANS

With Honeycomb Calandria

- Crystallizers engineered by Buckau-Wolf
- Buckau-Wolf Honeycomb Calandria as 'part of retrofit concept for existing systems
- Significant increase of heating surface up to 25 %
- Reduced deposition areas by about 75 %
- Capacity expansion as a result of shortened boiling time
- Optimum flow conditions ensure homogeneous liquor